

ELR H5-I-xx- 24DC/500AC-xx

Hybrid motor starter (CONTACTRON)

Data sheet
106113_en_01

© PHOENIX CONTACT 2017-01-26



1 Description

The 3-phase hybrid motor starter with reversing function and current monitoring provides the following functions.

- Forward running
- Reverse running
- Motor overload protection

The amount of cabling required is reduced to a minimum by the internal locking circuit and the load wiring.



Make sure you always use the latest documentation.
It can be downloaded from the product at phoenixcontact.net/products.



This document is valid for the products listed in the "Ordering data".

2	Table of contents	
1	Description	1
2	Table of contents	2
3	Ordering data	3
4	Technical data	6
5	Safety regulations and installation notes.....	8
	5.1 UL Notes	8
6	Operating and indication elements	9
7	Connection notes	9
	7.1 Mains connection and line protection	9
	7.2 Connecting cables	10
	7.3 Block diagram.....	10
8	Function.....	11
	8.1 Status and diagnostics indicators.....	11
	8.2 Diagnostic function.....	11
	8.3 Parameterization - Nominal current setting	13
9	Application examples	14
	9.1 Motor protection	14
	9.2 Motor with brake.....	14
	9.3 Auxiliary relay connection	14
10	Trigger characteristic	15
11	Derating curves for 100 % operating time.....	16

3 Ordering data

Description	Type	Order No.	Pcs./Pkt.
Hybrid motor starter for reversing 3~ AC motors up to 500 V AC and 0.6 A output current, with 24 V DC control voltage, adjustable overload shutdown, and push-in connection.	ELR H5-I-PT- 24DC/500AC-0,6	2903908	1
Hybrid motor starter for reversing 3~ AC motors up to 500 V AC and 2.4 A output current, with 24 V DC control voltage, adjustable overload shutdown, and push-in connection.	ELR H5-I-PT- 24DC/500AC-2	2903910	1
Hybrid motor starter for reversing 3~ AC motors up to 500 V AC and 9 A output current, with 24 V DC control voltage, adjustable overload shutdown, and push-in connection.	ELR H5-I-PT- 24DC/500AC-9	2903912	1
Hybrid motor starter for reversing 3~ AC motors up to 500 V AC and 0.6 A output current, with 24 V DC control voltage, adjustable overload shutdown, and screw connection.	ELR H5-I-SC- 24DC/500AC-0,6	2900573	1
Hybrid motor starter for reversing 3~ AC motors up to 500 V AC and 2.4 A output current, with 24 V DC control voltage, adjustable overload shutdown, and screw connection.	ELR H5-I-SC- 24DC/500AC-2	2900574	1
Hybrid motor starter for reversing 3~ AC motors up to 500 V AC and 9 A output current, with 24 V DC control voltage, adjustable overload shutdown, and screw connection.	ELR H5-I-SC- 24DC/500AC-9	2900576	1
Accessories	Type	Order No.	Pcs./Pkt.
3-phase loop bridge for 2 CONTACTRON modules, with push-in connection and 22.5 mm housing width, connecting cable: 3 m, with ferrules included.	BRIDGE-PT 2	2904490	1
3-phase loop bridge for 3 CONTACTRON modules, with push-in connection and 22.5 mm housing width, connecting cable: 3 m, with ferrules included.	BRIDGE-PT 3	2904491	1
3-phase loop bridge for 4 CONTACTRON modules, with push-in connection and 22.5 mm housing width, connecting cable: 3 m, with ferrules included.	BRIDGE-PT 4	2904492	1
3-phase loop bridge for 5 CONTACTRON modules, with push-in connection and 22.5 mm housing width, connecting cable: 3 m, with ferrules included.	BRIDGE-PT 5	2904493	1
3-phase loop bridge for 6 CONTACTRON modules, with push-in connection and 22.5 mm housing width, connecting cable: 3 m, with ferrules included.	BRIDGE-PT 6	2904494	1
3-phase loop bridge for 7 CONTACTRON modules, with push-in connection and 22.5 mm housing width, connecting cable: 3 m, with ferrules included.	BRIDGE-PT 7	2904495	1

Accessories	Type	Order No.	Pcs./Pkt.
3-phase loop bridge for 8 CONTACTRON modules, with push-in connection and 22.5 mm housing width, connecting cable: 3 m, with ferrules included.	BRIDGE-PT 8	2904496	1
3-phase loop bridge for 9 CONTACTRON modules, with push-in connection and 22.5 mm housing width, connecting cable: 3 m, with ferrules included.	BRIDGE-PT 9	2904497	1
3-phase loop bridge for 10 CONTACTRON modules, with push-in connection and 22.5 mm housing width, connecting cable: 3 m, with ferrules included.	BRIDGE-PT 10	2904498	1
The BRIDGE COVER covering hood is used to cover unused plugs on the CONTACTRON bridge that may subsequently be used to extend the system. The hood can be used with the screw and Push-in version of the bridge.	BRIDGE COVER	2906240	10
3-phase loop bridge for 2 CONTACTRON modules, with screw connection and 22.5 mm housing width, connecting cable: 0.3 m, with ferrules.	BRIDGE- 2	2900746	1
3-phase loop bridge for 3 CONTACTRON modules, with screw connection and 22.5 mm housing width, connecting cable: 0.3 m, with ferrules.	BRIDGE- 3	2900747	1
3-phase loop bridge for 4 CONTACTRON modules, with screw connection and 22.5 mm housing width, connecting cable: 0.3 m, with ferrules.	BRIDGE- 4	2900748	1
3-phase loop bridge for 5 CONTACTRON modules, with screw connection and 22.5 mm housing width, connecting cable: 0.3 m, with ferrules.	BRIDGE- 5	2900749	1
3-phase loop bridge for 6 CONTACTRON modules, with screw connection and 22.5 mm housing width, connecting cable: 0.3 m, with ferrules.	BRIDGE- 6	2900750	1
3-phase loop bridge for 7 CONTACTRON modules, with screw connection and 22.5 mm housing width, connecting cable: 0.3 m, with ferrules.	BRIDGE- 7	2900751	1
3-phase loop bridge for 8 CONTACTRON modules, with screw connection and 22.5 mm housing width, connecting cable: 0.3 m, with ferrules.	BRIDGE- 8	2900752	1
3-phase loop bridge for 9 CONTACTRON modules, with screw connection and 22.5 mm housing width, connecting cable: 0.3 m, with ferrules.	BRIDGE- 9	2900753	1
3-phase loop bridge for 10 CONTACTRON modules, with screw connection and 22.5 mm housing width, connecting cable: 0.3 m, with ferrules.	BRIDGE-10	2900754	1
3-phase loop bridge for 2 CONTACTRON modules, with screw connection and 22.5 mm housing width, connecting cable: 3 m, with ferrules included.	BRIDGE- 2-3M	2901543	1
3-phase loop bridge for 3 CONTACTRON modules, with screw connection and 22.5 mm housing width, connecting cable: 3 m, with ferrules included.	BRIDGE- 3-3M	2901656	1

Accessories	Type	Order No.	Pcs./Pkt.
3-phase loop bridge for 4 CONTACTRON modules, with screw connection and 22.5 mm housing width, connecting cable: 3 m, with ferrules included.	BRIDGE- 4-3M	2901659	1
3-phase loop bridge for 5 CONTACTRON modules, with screw connection and 22.5 mm housing width, connecting cable: 3 m, with ferrules included.	BRIDGE- 5-3M	2901545	1
3-phase loop bridge for 6 CONTACTRON modules, with screw connection and 22.5 mm housing width, connecting cable: 3 m, with ferrules included.	BRIDGE- 6-3M	2901697	1
3-phase loop bridge for 7 CONTACTRON modules, with screw connection and 22.5 mm housing width, connecting cable: 3 m, with ferrules included.	BRIDGE- 7-3M	2901698	1
3-phase loop bridge for 8 CONTACTRON modules, with screw connection and 22.5 mm housing width, connecting cable: 3 m, with ferrules included.	BRIDGE- 8-3M	2901700	1
3-phase loop bridge for 9 CONTACTRON modules, with screw connection and 22.5 mm housing width, connecting cable: 3 m, with ferrules included.	BRIDGE- 9-3M	2901701	1
3-phase loop bridge for 10 CONTACTRON modules, with screw connection and 22.5 mm housing width, connecting cable: 3 m, with ferrules included.	BRIDGE-10-3M	2901702	1
3-phase loop bridge for 2 modules from the CONTACTRON family with screw connection and 22.5 mm housing width, 1 m long connecting cable, without ferrules.	BRIDGE- 2-1M	2901542	1
3-phase loop bridge for 3 modules from the CONTACTRON family with screw connection and 22.5 mm housing width, 1 m long connecting cable, without ferrules.	BRIDGE- 3-1M	2901655	1
3-phase loop bridge for 4 modules from the CONTACTRON family with screw connection and 22.5 mm housing width, 1 m long connecting cable, without ferrules.	BRIDGE- 4-1M	2901658	1
3-phase loop bridge for 5 modules from the CONTACTRON family with screw connection and 22.5 mm housing width, 1 m long connecting cable, without ferrules.	BRIDGE- 5-1M	2901544	1
3-phase loop bridge for 6 modules in the CONTACTRON family with 1 m long connecting cable without ferrules, 22.5 mm housing width.	BRIDGE- 6-1M	2901649	1

4 Technical data

Device supply	
Rated control circuit supply voltage U_S	24 V DC
Control supply voltage range	19.2 V DC ... 30 V DC
Rated control supply current I_S	40 mA
Protective circuit	Reverse polarity protection Surge protection
Control input right/left	
Rated actuating voltage U_C	24 V DC
Rated actuating current I_C	5 mA (Input type 1)
Switching threshold	9.6 V ("0" signal) 19.2 V ("1" signal)
Protective circuit	Reverse polarity protection
Typical turn-off time	< 30 ms
AC output	
Rated operating voltage U_e	500 V AC (50 Hz / 60 Hz)
Operating voltage range	42 V AC ... 550 V AC
Load current range see to derating	75 mA ... 600 mA / 180 mA ... 2.4 A / 1.5 A ... 9 A
Trigger characteristic in acc. with IEC 60947-4-2	Class 10A / Class 10A / Class 10A
Cooling time	20 min. (for auto reset)
Rated operating current at AC-51	0.6 A / 2.4 A / 9 A
Rated operating current at AC-53a	0.6 A / 2.4 A / 6.5 A
Leakage current	0 mA / 0 mA / 0 mA
Protective circuit	Surge protection
Acknowledge output	
Confirmation: floating change-over contact, signal contact	
Switching capacity according to IEC 60947-5-1	3 A (230 V, AC15) 2 A (24 V, DC13)
Status and diagnostics indicators	
Status display	Yellow LED
Indication	Red LED
General data	
Mounting position	vertical (horizontal DIN rail, motor output below)
Mounting	alignable, for spacing see derating
Operating mode	100% operating factor
Degree of protection	IP20
Power dissipation min./max.	0.88 W / 2.5 W ; 0.88 W / 4.1 W ; 0.88 W / 7 W
Dimensions W/H/D	22.5 mm / 99 mm / 114.5 mm

Connection data		Push-in connection	Screw connection
Connection name		Control circuits	Control circuits
Conductor cross section, solid		0.2 mm ² ... 2.5 mm ²	0.2 mm ² ... 2.5 mm ²
Conductor cross section, flexible		0.2 mm ² ... 2.5 mm ²	0.2 mm ² ... 2.5 mm ²
Conductor cross section [AWG]		24 ... 14	24 ... 14
Tightening torque			0.5 Nm ... 0.6 Nm
Connection name		Load circuit	Load circuit
Conductor cross section, solid		0.2 mm ² ... 2.5 mm ²	0.2 mm ² ... 2.5 mm ²
Conductor cross section, flexible		0.2 mm ² ... 2.5 mm ²	0.2 mm ² ... 2.5 mm ²
Conductor cross section [AWG]		24 ... 14	24 ... 14
Tightening torque			0.5 Nm ... 0.6 Nm
Stripping length		10 mm	8 mm
Ambient conditions			
Ambient temperature (operation)		-25 °C ... 70 °C (observe derating)	
Ambient temperature (storage/transport)		-40 °C ... 80 °C	
Standards/regulations			
Standards		IEC 60947-1 IEC 60947-4-2 IEC 61508 ISO 13849	
Insulation characteristics			
Rated insulation voltage		500 V	
Rated surge voltage / insulation		6 kV	
Insulation characteristics between the control input and control supply voltage, and auxiliary circuit to the main circuit		Safe isolation (IEC 60947-1) at operating voltage ≤ 300 V AC (e.g., 230/400 V AC, 277/480 V AC) Safe isolation (EN 50178) at operating voltage ≤ 300 V A (e.g., 230/400 V AC, 277/480 V AC) Basic isolation (IEC 60947-1) at operating voltage 300 ... 500 V AC Safe isolation (EN 50178) at operating voltage 300 ... 500 V AC	
Isolation characteristics between the control input and control supply voltage to auxiliary circuit		Safe isolation (IEC 60947-1) in the auxiliary circuit ≤ 300 V AC Safe isolation (EN 50178) in the auxiliary circuit ≤ 300 V AC	
Degree of pollution		2	
Conformance/Approvals			
UL, USA/Canada		NLDX.E228652	

5 Safety regulations and installation notes

- When working on the device, observe the national safety and accident prevention regulations.
- Disregarding these safety regulations may result in death, serious personal injury or damage to equipment.
- Startup, mounting, modifications, and upgrades should only be carried out by a skilled electrical engineer!
- Disconnect the power to the module.
- During operation, parts of electrical switching devices carry hazardous voltages.
- During operation, the protective covers must not be removed from the electric switchgear.
- Keep the product documentation in a safe place.
- The device is an associated item of equipment. Do not install the device in potentially explosive areas. When installing and operating associated equipment, the applicable safety directives must be observed.
- If you use the "Automatic RESET" operating mode, the drive is switched on again after the cooling time has ended if a control signal is still present. The cooling time is 20 minutes.
- The equipment must not be exposed to mechanical or thermal influences that exceed the limits as described in the operating instructions. If required, the device should be installed in an appropriate housing with a suitable degree of protection (e. g. IP54) according to IEC 60529/EN 60529 to provide protection against mechanical and electrical damage. Where dust is present, the device must be installed in suitable housing (IP64, minimum) according to EN 50281.
- Install the device according to the instructions in the installation instructions. Access to circuits within the device is not permitted.
- The operating equipment cannot be repaired by the user and must be replaced by an equivalent device. Repairs may only be carried out by the manufacturer.
- The device executes a function diagnosis when the drive is switched on or is in the switched on state. In addition, an authorized electrician or a skilled worker who is well acquainted with the relevant standards can conduct the "Motor overload protection" safety function test. For this test, the drive must be operated with right or left rotation (forward or reverse running), and the current flow in a conductor is interrupted (e.g. by removing the fuse in the L1 or L3 phase). The hybrid motor starter then switches off the drive within 1.5 to 2 s. The LEDs for right or left rotation go out, and the ERR-LED and the reply output are set.
- Only use power supply units with safe isolation with SELV / PELV voltage in accordance with EN 50178/ VDE 0160(SELV / PELV). This prevents short circuits between primary and secondary sides.

- Observe the minimum permissible load current in safety-related applications:
 ELR H3-.../500AC-06: ≥ 75 mA
 ELR H3-.../500AC-3: ≥ 180 mA
 ELR H3-.../500AC-9: ≥ 1.5 A

Area of application

- In circuits in potentially dust-explosive areas of zones 21 and 22, it must be guaranteed that the equipment connected to this circuit complies with category 2D or 3D or is certified as such.
- This is a product for environment A (industry). The device can cause unwanted radio interference if used in Class B environments (household). In this case, the user may be obligated to take the necessary precautionary measures.

5.1 UL Notes



WARNING: Risk of electric shock and fire

The opening of the branch-circuit protective device may be an indication that a fault current has been interrupted.

To reduce the risk of fire or electric shock, current-carrying parts and the other components of the controller should be examined and replaced if damaged.

Failure to follow instructions can result in death, serious injury, or equipment damage.



NOTE

For use with a "low voltage, limited energy, isolated power supply" use copper cables approved to at least 75 °C.

The device is designed for use with a "low voltage, limited energy, isolated power supply".

SCCR (single and group installation)

Suitable for use on a circuit capable of delivering not more than 5 kA rms symmetrical amperes, 500 Volts maximum when protected by a 20 A class RK5 fuse (coordination type 1).

Suitable for use on a circuit capable of delivering not more than 100 kA rms symmetrical amperes, 500 Volts maximum when protected by a 30 A class J or class CC fuse (coordination type 1).

FLA	0.6 A (500 V AC) / 2.4 A (500 V AC) / 6.5 A (500 V AC)
-----	--

6 Operating and indication elements

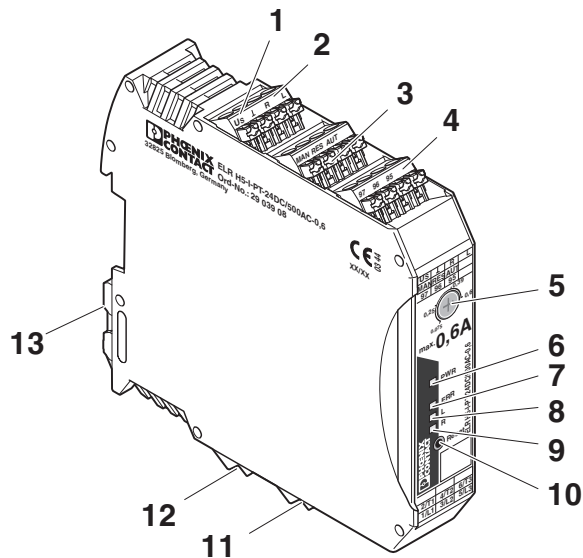

Figure 1 Operating and indication elements

- 1 Input: Control supply voltage
- 2 Control input: Forward/reverse running
- 3 Acknowledgment inputs MAN, RES, AUT
- 4 Feedback
- 5 Potentiometer for nominal current parameterization
- 6 LED PWR: Control supply voltage
- 7 LED ERR: Message/error
- 8 LED L: Reverse running
- 9 LED R: Forward running
- 10 Reset button
- 11 3-phase output voltage
- 12 3-phase input voltage
- 13 Metal lock for fixing to DIN rail

7 Connection notes



WARNING: Danger to life by electric shock!

Never carry out work when voltage is present.

7.1 Mains connection and line protection

- When connecting the 3-phase network, it is essential to observe the terminal identification.
- The following specifications apply for the fuses used.

25 A gG / 10 kA / 500 V	Coordination type 1
16 A B-circuit breaker / 1.5 kA / 400 V	Coordination type 1
30 A CC / 30 kA / 500 V	Coordination type 1
16 A FA (6.3 x 32 mm) / 1.5 kA / 500 V	Coordination type 2
16 A FF / gR (10 x 38 mm) / 10 kA / 500 V	Coordination type 2

- The control supply voltage and control voltage inputs must be operated with power supply modules according to IEC 61131-2 (max. 5 % residual ripple).
- In order to avoid inductive or capacitive coupling of noise emissions where long control wires are used, we recommend the use of shielded conductors.



NOTE: Electrical safety

Screw connection:

Only connect conductors with the same conductor cross section to a terminal point.

Push-in connection:

Only connect a conductor to a terminal point or use conductors with the same conductor cross section ferrules.

7.2 Connecting cables

Push-in connection:

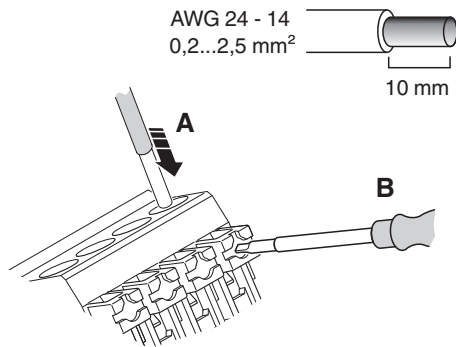

Figure 2 Push-in connection

Insert solid or stranded conductors with ferrules directly in the clamping space (A). Reliable contact can be made with stranded conductors without ferrules by opening the spring beforehand using the pushbutton (B). Press the pushbutton (B) also to release the conductor.

Screw connection:

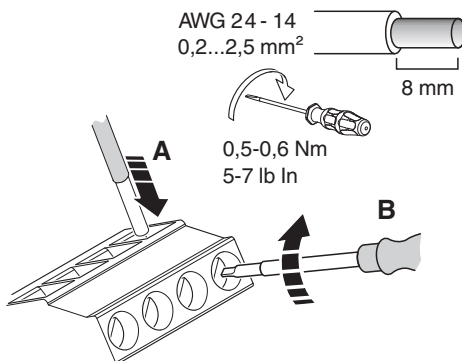

Figure 3 Screw connection

- Strip off each individual wire to 8 mm.
- Insert the wire into the corresponding connection terminal block.
- Use a screwdriver to tighten the screw in the opening above the connection terminal block.

7.3 Block diagram

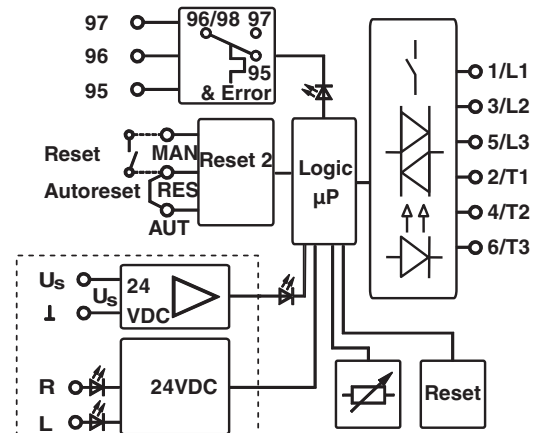

Figure 4 Block diagram

8 Function

8.1 Status and diagnostics indicators

The device visualizes the operating statuses with a total of four LEDs.

LED PWR	Green	Device status
LED L	Yellow	Reverse running
LED R	Yellow	Forward running
LED ERR	Red	Internal or external error
		Process errors: overcurrent, asymmetry, phase failure

After applying the control supply voltage, all LEDs light up once as an LED test.

8.2 Diagnostic function

Various diagnostic functions enable the hybrid motor starter to detect many internal errors and also external errors (I/O errors).

If an error is detected, the device is switched to the safe shutdown state.

You cannot acknowledge internal errors. They are stored in the device. Afterwards the device cannot be started up again.

In case of external errors, an error acknowledgment is required to exit the safe shutdown state.

The flashing PWR LED indicates a message.

In case of a message, the power path remains switched on; an acknowledgement is not required.

Explanation: A = LED switched off / E = LED lights continuously / B = LED flashes ca. 2 Hz (50:50) / Aut = Automatic / Man = Manual / Nm = Not possible / Ne = Not required

Status	Description	PWR	ERR	L	R	Error acknowledgment
		Green	Red	Yellow		
OFF	Supply voltage not present	A	A	A	A	-
Ready to operate	Supply voltage present	E	A	A	A	-
Drive switched on	Reverse running (L)	E	A	E	A	-
	Forward running (R)	E	A	A	E	-
Internal error	Internal device error - device replacement required	E	E	A	A	Nm
External error in controller or I/O devices (maintenance requirement)	Motor protection function: The motor current is higher than the motor nominal current specification: Cooling time elapsing (20 minutes)					
	Error during reverse running	E	B	E	A	Aut
	Error during forward running	E	B	A	E	Aut
	After 2 minutes, "L" or "R" flashes: manual reset is possible					
	Error during reverse running	E	B	B	A	Man
	Error during forward running	E	B	A	B	Man
	Error restoring the system state: Checksum error. The thermal memory of the motor protection function is set to the maximum value. The error must be manually acknowledged.	E	B	B	B	Man
	Symmetry: The two motor currents deviate from each other by more than 33 %.	E	B	A	A	Man
	Blocking: The max. measurable motor current is exceeded for more than 2 s.					
	Error during reverse running	E	B	B	A	Man
Error during forward running	E	B	A	B	Man	
Message (power path remains switched on)	Message with pending control signal: - 2 or more phases are missing - No motor connected - Motor current in at least two phases > 2 s below the minimum current value that can be set					
	Message during reverse running	B	B	E	A	Ne
	Message during forward running	B	B	A	E	Ne

Error acknowledgment

The following options are available for error acknowledgment.

Manual (reset button)

Press the reset button on the front of the device.

When pressing the reset button for more than 2 s (approximately), the device returns to the error state.

Pressing the reset button for more than 6 s changes the device to the "Parameterization" mode.

Manual (remote acknowledgment point)

Connect a button (N/O contact) between the MAN and RES terminals.

An acknowledgement is triggered as soon as a positive edge is detected at the MAN input. If no negative edge is detected after approx. 2 s, the device adopts an error state since manipulation or an error in the acknowledgment circuit may have occurred.

Automatic

Establish an electrical connection between the RES and AUT terminals.

Following triggering of motor protection monitoring and subsequent cooling, the device performs an automatic acknowledgment.



The RES terminal provides the voltage for the reset.
In variants with a rated control supply voltage of 24 V DC, this is 24 V DC.



NOTE: device damage
Only connect conductors to the terminals MAN, RES and AUT which are a maximum of 30 m long.

Feedback

As soon as the device detects an error or indicates a message, the reply relay is switched, i.e. the N/O contact is closed or the N/C contact is opened. This behavior matches that of a motor protection switch or motor protection relay.

8.3 Parameterization - Nominal current setting

- Press the reset button for more than 6 s to change to the "Parameterization" mode. The green PWR flashes once.

In the Parameterization mode, the LEDs are switched off every 2 s for 0.3 s to distinguish this mode from other operating modes.

- Set the nominal drive current with the 240° potentiometer. The nominal current is specified in 16 stages. The four LEDs show the set current.

Code				Nominal current [mA]		
PWR	ERR	L	R	0.6 A	2 A	9 A
0	0	0	0	75	180	1500
0	0	0	1	110	250	2000
0	0	1	0	145	410	2500
0	0	1	1	180	560	3000
0	1	0	0	215	710	3500
0	1	0	1	250	870	4000
0	1	1	0	285	1020	4500
0	1	1	1	320	1170	5000
1	0	0	0	355	1330	5500
1	0	0	1	390	1480	6000
1	0	1	0	425	1630	6500
1	0	1	1	460	1790	7000
1	1	0	0	495	1940	7500
1	1	0	1	530	2090	8000
1	1	1	0	565	2250	8500
1	1	1	1	600	2400	9000

- Store this value by pressing the reset button again (non-volatile area of the mass storage).
- Press the reset button for more than 2 s (and less than 6 s) to display the set current for 3 s. This function is only possible if 1) the device is not activated, and 2) there is no error at the device.

9 Application examples



NOTE

Switching off the control voltage supply with a controlled motor always results in wear in the hybrid motor starter.

This type of switching off should only be used if no more than 10,000 shutdowns can be expected over the entire lifetime of the system.

9.1 Motor protection

All safety-related functions are implemented by the hybrid motor starter without external influences. Special circuit technology is not required.

If the motor currents deviate by more than 33 %, the motor shuts down within 2 minutes.

If the motor currents deviate by more than ≥ 67 %, (e.g., phase failure), the motor shuts down within 2 seconds.

The deviation can be calculated using the following formulas.

$$\text{Value } (I_{\max}) > I_{\text{nom}} \Rightarrow (I_{\max} - I_{\min})/I_{\max}$$

$$\text{Value } (I_{\max}) < I_{\text{nom}} \Rightarrow (I_{\max} - I_{\min})/I_{\text{nom}}$$



In the event of high clock rates, the motor protection function may trip due to the increased switch-on currents

9.2 Motor with brake

If a motor with brake (connection in the motor terminal board) is connected, the 400 V AC brake must be linked to the 2/T1 and 6/T3 terminals. A 230 V AC brake must be connected to the 4/T2 terminals and the star point of the motor.



NOTE

Increase motor current monitoring to the nominal brake current. This should be set accordingly on the hybrid motor starter.

9.3 Auxiliary relay connection

Auxiliary relay (e. g. PLC RSC 230UC/21, order no.: 2966207) for activating external brakes or acknowledgements, e. g. to the PLC, must be connected to the 4T2 and N connections of the system.

10 Trigger characteristic

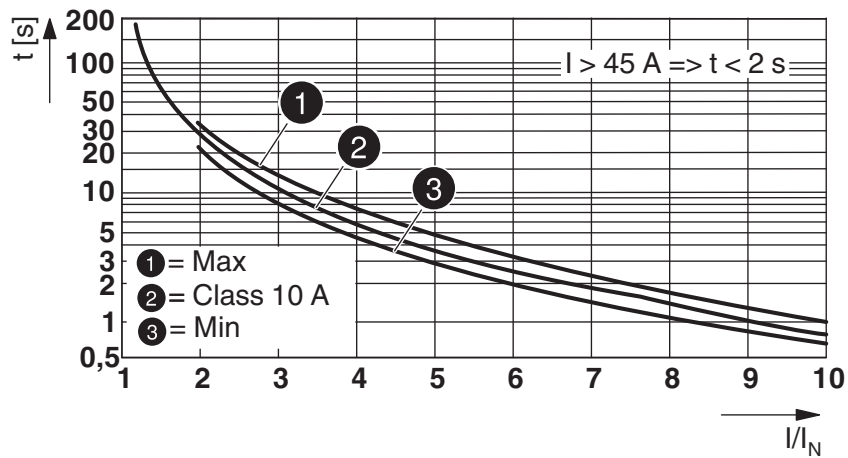

Figure 5 Trigger characteristic

t [s] Release time in seconds

I/I_N Overcurrent factor: the ratio between the actual current and the parameterized nominal current

11 Derating curves for 100 % operating time

Additional data is available on request.

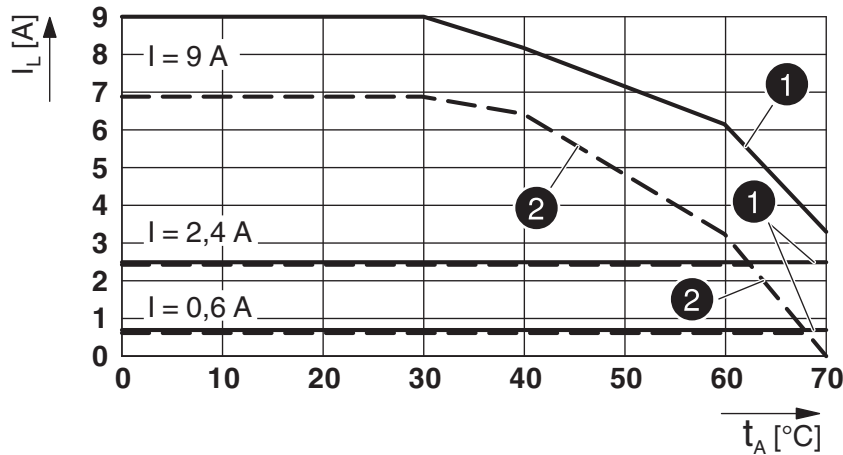

Figure 6 Derating curve

- I_L = Load current [A]
- t_A = Ambient temperature [°C]
- I_A = Starting current [A]
- ① = Aligned with 20 mm spacing
- ② = Aligned without spacing

The adjustment factors described here refer to hybrid motor starters with a maximum load current of 9 A. You can determine the maximum permissible rated current of the motor using the load current, the overcurrent factor (see data sheet of the relevant motor), and the 9 A derating curve.

9 A derating curve										
Overcurrent factor I_A/I_N	1	2	3	4	5	6	7	8	9	10
Adjustment factor K	1	1	1	1	1	0.96	0.83	0.72	0.64	0.58

Example 1	
Motor with overcurrent factor I_A/I_N (from motor data sheet)	8
Adjustment factor K	0.72
Max. permissible load current I_L at 30°C, not aligned (from derating curve)	9 A
Max. permissible rated current I_N of the motor	6.5 A

Example 2	
Motor with overcurrent factor I_A/I_N (from motor data sheet)	5
Adjustment factor K	1
Max. permissible load current I_L at 60°C, aligned (from derating curve)	3.2 A
Max. permissible rated current I_N of the motor	3.2 A